

ADDENDUM #2 – APRIL 12, 2023

RE: **COQUILLE HIGH SCHOOL**
CTE Shop Renovation
Project #21.03

FROM: HGE ARCHITECTS, Inc.
333 South 4th Street
Coos Bay, Oregon 97420
541-269-1166



TO: Prospective Bidders

This Addendum forms a part of the Contract Documents and modifies the original Documents dated March 2023, as noted below. Acknowledge receipt of this Addendum in the space provided on the Bid Form. Failure to do so may subject Bidder to disqualification.

This Addendum consists of **TWO (2)** page(s) together with the following attachments:

- Sketch SK-01 Steel Bracket

CHANGES TO PROJECT MANUAL:

1. **Section 00-1113 Advertisement for Bids:** CHANGE Bid Closing “2:00 P.M., Thursday, April 20, 2023” to “11:00 A.M., Thursday, April 27, 2023”
2. **Section 09-0501 Room Finish Schedule:** Change Toilet Room 109 Base to “COVE” in lieu of “CONC”.

CHANGES TO DRAWINGS:

1. **Sheet A1.1 Site Plan – Master Plan, Sheet Index:** Make the following changes:
 - a. ADD Sheet FP 1.0 Fire Sprinkler Plan
 - b. DELETE Sheet M6.1 Mechanical Detail
2. **Sheet A2.2 Demo Floor Plan:** Make the following changes:
 - a. REMOVE ALL wood flooring and sleepers in Toilet/Custodial/Lobby area.
 - b. REMOVE door from Yearbook into Art Room, Door 101.
 - c. RELOCATE window removed for Toilet Room to former Door 101 location.
3. **Sheet A2.3 Floor Plan:** Make the following changes:
 - a. RENAME door from CTE Lobby to CTE Classroom “Door 111A”. Refer to Door Schedule for description and hardware group.
 - b. RENAME opening into CPU Lab “Door 111C”.
 - c. Per demo notes above, RELOCATE window, finishes to match, into Door 101 location.
 - d. Beam for stair landing at Mechanical Mezzanine to be 4x12 per Section 3/A3.1. Provide 4x12 header at Door/Sidelight 103A.

- e. See attached sketch SK-01, regarding beam/column connection for 5 ½” x 12” glulam beam in CTE Lobby 110.
- f. AGR/MACH. CLASSROOM 103: CHANGE stainless steel counter and sink to “Owner Furnished, Contractor Installed”.

SUBSTITUTION APPROVALS:

<u>SPECIFIED SECTION</u>	<u>SPECIFIED ITEM</u>	<u>APPROVED</u>
07-2500 Water-Resistive Barrier	Membrane	Air-Shield SMP

END OF ADDENDUM #2

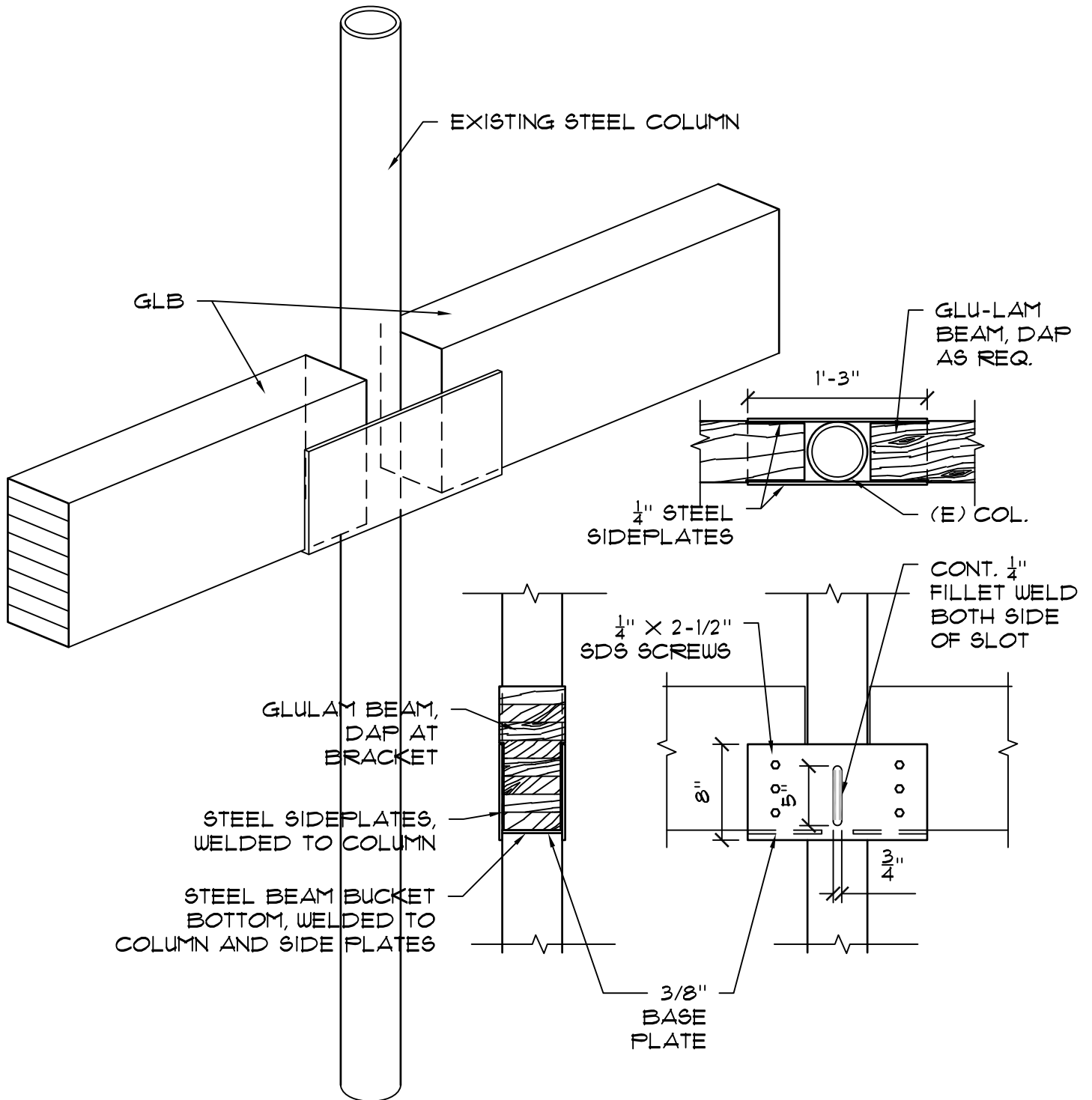

HGE
ARCHITECTS, INC.

333 S. 4TH STREET
COOS BAY, OR 97420
P: 541.269.1166
general@hge1.com
www.hge1.com

REGISTERED ARCHITECT
2840
JOSEPH A. SLACK
Joseph A. Slack
COOS BAY,
OREGON
STATE OF OREGON

PROJECT NO.: 21.03
HIGH SCHOOL CTE/SHOP REMODEL

COQUILLE SCHOOL DISTRICT
COQUILLE, OREGON

SHEET TITLE:
STEEL BRACKET

DATE:
4/12/2023

SK-01

Copyright © 2023,
HGE ARCHITECTS, INC.